

FIRE PROTECTION REELS



1" AND 1 1/2" HOSE
SPOKE RIM OR CRANK MANUAL REWIND

Standard reels

- Ductile iron swivel joint
- Red powder coat finish
- Ductile iron quick release brake (rim rewind)

Optional

- Hot dip galvanized or aluminum
- Brass swivel joint

American Reels fire protection hose reels are an essential component of any fire protection system. They are designed to store and dispense fire hoses quickly and efficiently, allowing quick access in the event of a fire emergency. These hose reels are typically mounted in strategic locations throughout a building, ensuring they are easily accessible wherever needed.

Fire protection hose reels come in a variety of sizes and configurations to suit different needs and can be made from a variety of materials, including steel, and aluminum.

In addition to providing easy access to fire hoses, fire protection hose reels can also help to keep hoses organized and prevent kinks and tangles that can reduce their effectiveness in a fire emergency.

Fire protection hose reels are a critical component of any fire protection system, helping to ensure you have quick and reliable access to the tools you need to combat fires and protect lives and property.

RUGGED BY DESIGN

775.246.1000 | WWW.AMERICANREELS.COM

FIRE PROTECTION REELS

1" AND 1 1/2" HOSE

SPOKE RIM OR CRANK MANUAL REWIND

When ordering - Please supply the following information.

1. Model number of reel
2. Right hand inlet is standard (for left hand, please specify)
3. Top or bottom wind
4. Product to be handled
5. To specify the hose diameter when ordering, add "-10" for a 1" hose or "-15" for a 1.5" hose at the end of the model number.
6. If ordering a reel with a Brass Swivel Joint, be sure to include "-B" at the end of the model number.

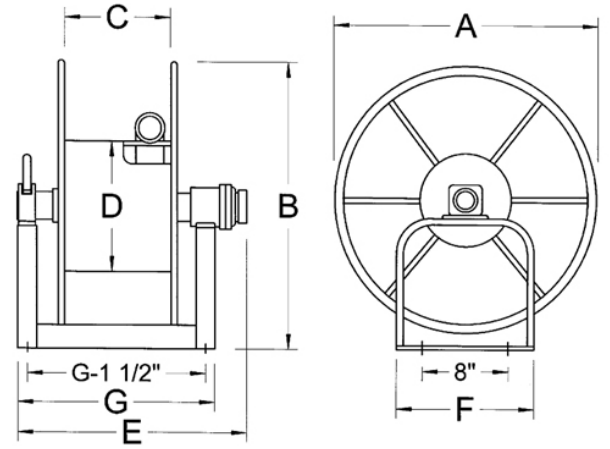

NOTE: Mounting holes in frame are 27/64".

Rim Rewind Model	Crank Rewind Model	Hose I.D.		Dimensions in Inches								
		1"	1.5"	A	B	C	D	E	FR	FC	G	H
FR1110-28	FC1110-28	100'	50'	28	29 1/2	10	11	20	12	20	17	15 1/2
FR1125-22	FC1125-22	150'	75'	22	23 1/2	25	11	35	12	20	32	12 1/2
FR1115-28	FC1115-28	200'	100'	28	29 1/2	15	11	25	12	20	22	15 1/2
FR1120-25	FC1120-25	200'	100'	25	26 1/2	20	11	30	12	20	27	14
FR1120-28	FC1120-28	250'	150'	28	29 1/2	20	11	30	12	20	27	15 1/2
FR1125-28	FC1125-28	300'	200'	28	29 1/2	25	11	35	12	20	32	15 1/2

Specifications are subject to change without notice.



American Reels is a brand of
United Equipment Accessories, Inc.

15 Airpark Vista Blvd • Dayton, NV 89403 • 775-246-1000

www.americanreels.com • sales@americanreels.com

Copyright © 2025 United Equipment Accessories, Inc.